

# ATV OWNERS MANUAL

## WARNING!

ADULT ASSEMBLY REQUIRED.  
TO BE USED UNDER CONSTANT ADULT SUPERVISION.  
ALWAYS WEAR A HELMET AND PROTECTIVE EQUIPMENT.  
ALWAYS WEAR SHOES.  
DO NOT RIDE AT NIGHT OR IN WET WEATHER.  
NEVER USE ON PUBLIC ROADS, HILLS, SLOPED DRIVEWAYS, NEAR MOTOR VEHICLES OR SWIMMING POOLS.  
ALWAYS OBEY YOUR LOCAL TRAFFIC LAWS AND REGULATIONS.  
ALWAYS CHECK WHEELS, SPACERS, CAPS BEFORE EVERY RIDE.  
REPLACE WORN AND DAMAGED PARTS IMMEDIATELY. DO NOT RIDE UNTIL PARTS HAVE BEEN REPLACED TO PREVENT INJURIES.  
ALLOW ONLY ONE RIDER.  
MAXIMUM USER WEIGHT LIMIT FOR THIS PRODUCT IS 20KG.  
SUITABLE FOR AGES 1-3 YEARS.  
WARNING! NOT SUITABLE FOR CHILDREN UNDER 3 YEARS PRIOR TO ASSEMBLY. CONTAINS SMALL PARTS.

## PARTS LIST

ITEM	DESCRIPTION	QTY
A	Chrome cap nuts	3
B	Cap nut tool 29mm	1
C	Plastic spacer 20mm	2
D	Plastic spacer 29mm	2
E	Handle bar	1
F	Main body	1
G	Plastic wheel Large	3
H	143mm steel axle with chrome cap nut	1
I	187mm steel axle with chrome cap nut	1
J	350mm steel axle with chrome cap nut	1

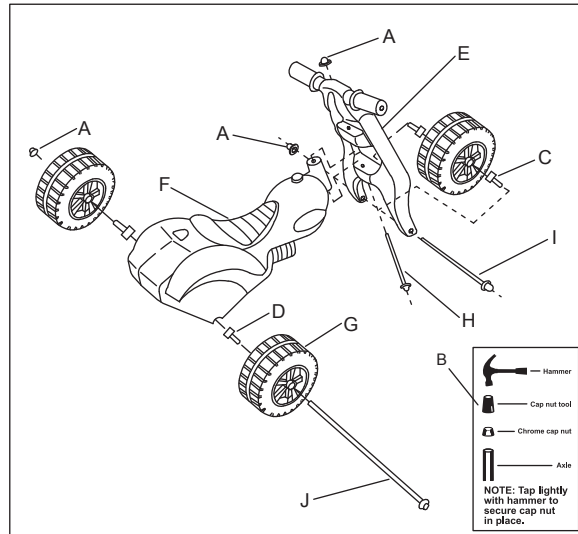

Please note: Hammer not included.

Thank you for your purchase of this product. If any parts are missing or damaged, please contact one of our Customer Service Representatives on:

**HYPER EXTENSION PTY LTD**  
100 Keilor Park Drive, Tullamarine, VIC 3043

1800 632 792 (AUSTRALIA)  
0800 623 792 (NEW ZEALAND)  
Email: [spares@hunterleisure.com.au](mailto:spares@hunterleisure.com.au)  
Visit: [www.momentumservicesco.com](http://www.momentumservicesco.com)

Read and follow all instructions. Keep this manual for future reference.

## ASSEMBLY INSTRUCTIONS

### Step 1

Place the head stem of the body into the middle of the fork.  
Ensure the steering limiter on the head stem fits into the space on the fork.

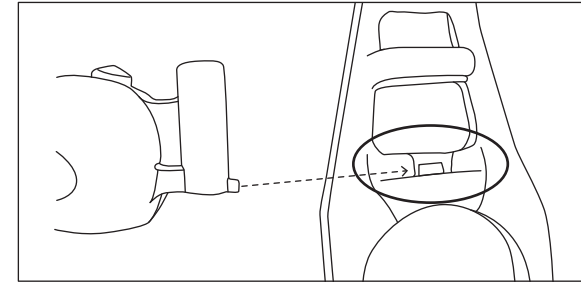

### Step 2

From the bottom of the fork, slide the 143mm axle through the fork and head stem. Pay attention and make sure holes are aligned so that the axle can slide all the way through. Tap the axle gently with a hammer if there is resistance threading the axle through. Make sure the axle stick out the other end.

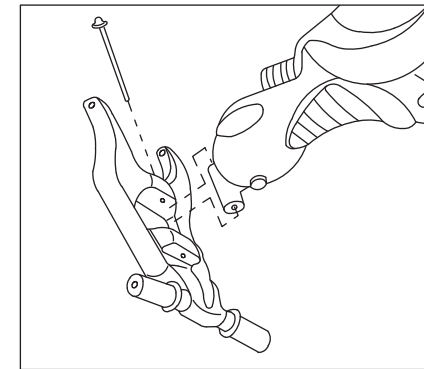

### Step 3

Turn the ATV upside down and place on a solid surface. Push the axle slightly back into the fork, allowing enough space for the cap nut tool to sit into the open space. Place a cap nut onto a cap nut tool. While holding the cap nut tool, rest it on the top bridge of the fork, then secure the axle in place by hammering the axle into the cap nut.

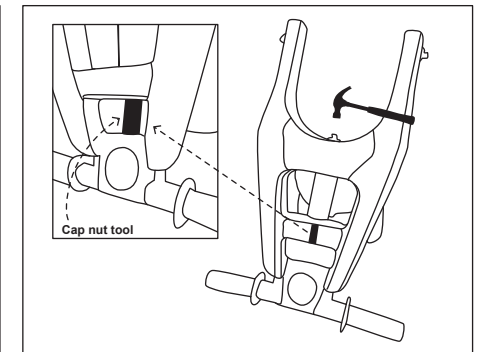
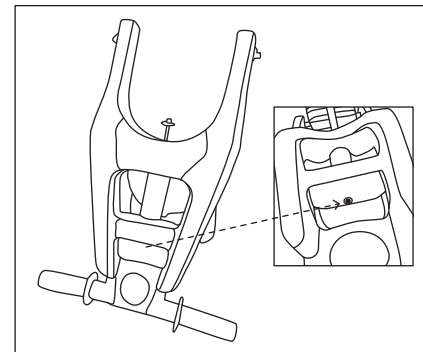

## ASSEMBLY INSTRUCTIONS

### Step 4

Slide the 187mm axle through the fork, 20mm spacer, wheel, 20mm spacer and through the other fork. Ensure that when installing the spacer, the wider end is resting against the wheel.  
**NOTE:** The product is designed to be tight fitting, so you may need to pull the forks outwards to make room.

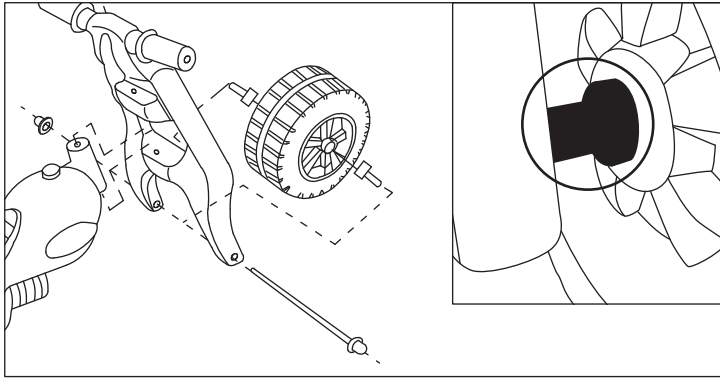

### Step 5

Turn the ATV on its side, with the capped end of the fork placed on a solid surface. Place a cap nut in the cap nut tool and hold at the top uncapped end of the axle. Using a hammer, tap the cap nut tool until the cap nut is securely fixed into the axle.

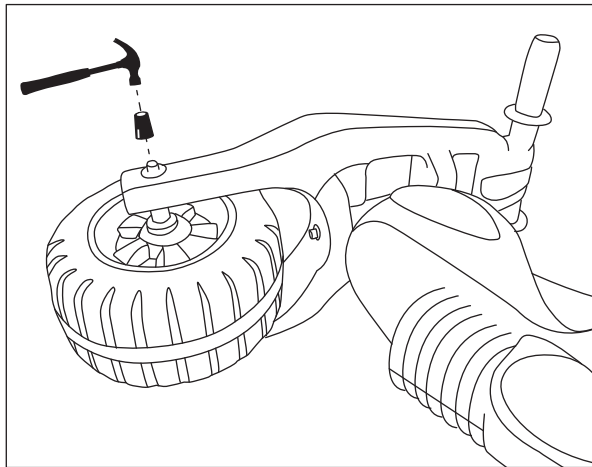

3.

## ASSEMBLY INSTRUCTIONS

### Step 6

Slide the 350mm axle through a wheel, 29mm spacer, ATV body, 29mm spacer and the second wheel.  
**NOTE:** Make sure the wider end of the spacer is resting up against both sides of the ATV body.

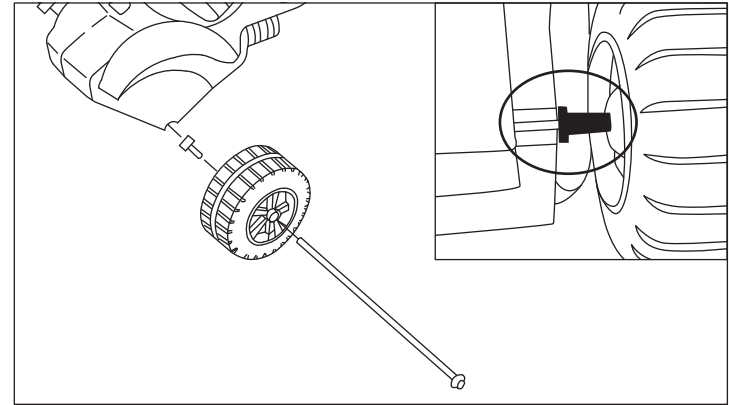

### Step 7

Turn the ATV on its side, with the capped end of the axle placed on a solid surface. Place a cap nut in the cap nut tool and hold at the top uncapped end of the axle. Using a hammer, tap the cap nut tool until the cap nut is securely fixed into the axle.

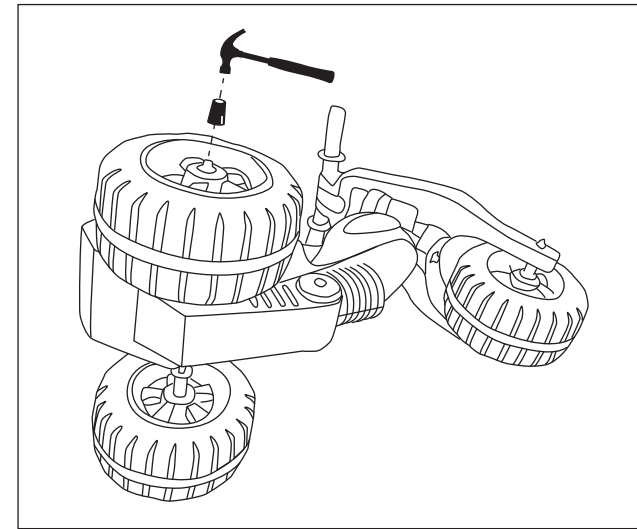

4.